

## ONYX 1000

Fully automated repair of SMD circuit boards  
up to 800 mm x 630 mm



# ONYX 1000

The ONYX 1000 is the only truly fully automated rework solution on a large platform that allows the entire process to be completed autonomously at the click of a mouse:

- Component removal.
- Site cleaning of residual solder with ZEVAC`s unique contactless solution to maintain pad quality.
- Solder paste dispensing with integrated dispensing head (optional).
- Component pick-up from automatic feeders and waffle trays.
- Fully automatic and precise component alignment and positioning (360° rotatable heads).
- Soldering process according to your predefined temperature profiles.
- All supported by closed-loop control systems and powerful, intuitive software.

## MAIN FEATURES

- **Large board handling for PCBs up to 630 mm x 800 mm.**
- **Automatic closed-loop force control of the Z-axis** for automatic pick and place, contactless site cleaning, fluxing, dispensing, soldering processes in order to protect sensitive parts.
- **All axes motorized** with closed-loop motion control.
- **State-of-the-art, easy to use and intuitive software including Vision Cognex Vpro license.**
- **Multifunctional robot head combining hot gas head + SMT pick & place head.**
- **Two automatic tool changers** for the hot gas head and the pick & place head.
- **MFOV system for high resolution inspection of components** up to 70 mm x 70 mm (optional 110 mm x 110 mm).
- **800 W multi-function hot gas heater head:**
  - Solder components, remove components, site clean (contactless and automatic removal of residual solder).
- **Adjustable bottom preheaters with a performance of up to 12'000 W** including integrated board cooling.
- **3 different controlled cooling systems** to control the temperature profile with the highest precision.
- **High precision closed-loop gas flow control** from 8 to 80 l/min.
- **Automatic contactless site cleaning** for removal of residual solder with a motorized X / Y / Z system.
- **Integrated dispensing head** (optional).
- **Automatic feeders and waffle trays** for component feeding.
- **Integrated dipping station** for flux and solder paste.
- **Eight thermocouple ports** for process temperature control.
- **Flexible board carrier for easy handling of irregularly shaped assemblies** without additional fixtures.

## **REDUCE OPERATOR INFLUENCE ON YOUR RESULTS**

Because the ONYX 1000 can run your entire process automatically, the operator is reduced to a supervisory role and does not influence the machine's results. Quality is assured and consistent, regardless of who starts the programme, and process knowledge is stored in the machine. The operator has time to ensure component availability and monitor multiple systems in parallel.

## **MORE WORKSPACE**

The ONYX 1000 is the evolution of the proven ONYX 500. Its flexibility has been further enhanced by the ability to divide the work area so that each process step can be carried out independently at its own temperature level. For example, a cold zone for dispensing applications using the integrated dispensing head, before moving the PCBs to a warm zone for soldering activities.

## **APPLICATION RANGE**

### **Repairs**

Misaligned equipment can be precisely repositioned and faulty components can be reliably replaced.

### **Prototyping**

The ONYX 1000 can automatically assemble and solder components on small and large PCBs with high efficiency. It allows the reuse of expensive components that have already been used.

### **Post-assembly**

Components that are missing at the time of assembly can be placed and soldered later, or individual components that cannot be handled by the existing production machines can be retrofitted with the ONYX 1000.

### **Assembly**

The ONYX 1000 provides an efficient solution for assembling PCBs with a small number of components.

### **Components**

ZEVAC's standard gas nozzles from the proven ONYX and DRS selective soldering machines can be used on the ONYX 1000 without modification. The ONYX 1000 can easily handle all electronic SMD components and all customer specific components.

### **Reuse, Recycle, Upcycle**

Salvage components from defective products, replace them, reball BGAs, update PCBs with the latest generations of components, upgrade, redesign, extend product life and reduce e-waste.

## TECHNICAL DATA

Product designation	ONYX 1000
Max. board size (W x D)	800 mm x 630 mm
Robot travel area	730 mm x 1200 mm
Board thickness range	Up to 10 mm
Max. component height	20 mm bottom side (30 mm optional) 48 mm top side (including board thickness)
Max. part size	Standard 70 mm x 70 mm (up to 110 mm x 110 mm optional)
Vision system object size	0.1 mm x 0.1 mm - 110 mm x 110 mm
Component and board illumination	Adjustable LED lights
Top heater power	800 W
Hot gas flow range	10 - 80 l/min (closed-loop controlled flow)
Preheater system	8 independent zones of 1500 W each Heated area: 650 mm x 860 mm
Hot gas pressure	4 – 6 bar
Temperature range	20 - 475 °C
Hot gas	Air or nitrogen
Cooling gas	Heater element by-pass pneumatic system
Power requirements	3 x 400 / 230 VAC 3 PNE 50 HZ 16 A
Controller	Computer controlled, Windows, VisualONYX™
Dimensions (W x D x H)	1820 mm x 1450 mm x 1720 mm
Weight	ca. 900 kg

## DIMENSIONS

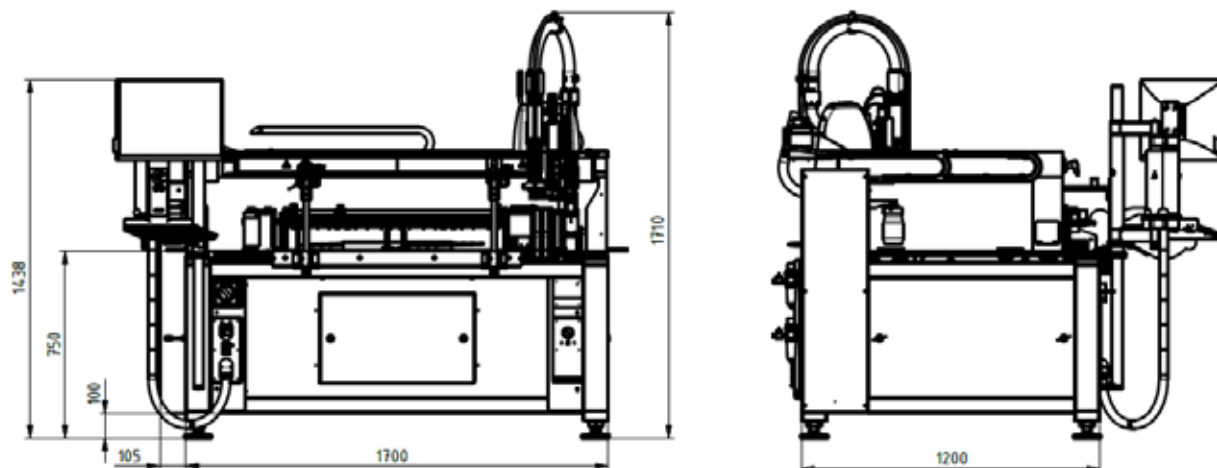

**ZEVAC**  
www.zevac.ch

info@zevac.ch



Vogelherdstrasse 4  
4500 Solothurn  
Switzerland

Tel. +41 32 626 20 80  
Fax +41 32 626 20 90

